



MUFU

More Unique For You

**BT22 Pro
Bluetooth Headset
User Manual**

Thank you for purchase MUFU BT22 Pro Bluetooth Headset. The content in this document is for informational purpose only and is subject to change without prior notice. We have made every effort to ensure that this User Manual is accurate and complete, however, no liability is assumed for any errors or omissions. The manufacturer reserves the right to change the technical specifications or accessories without prior notice. Please visit official website for the latest version of user manual.













Notice

- ❖ The friction scratches caused by the regular buckle of the main unit mount are normal and do not affect the use. Due to the production test, the main unit mount will have some micro-friction scratches. This is normal.
- ❖ To avoid the product damage or accidents from product dropping, install the product properly and solid before take a ride.
- ❖ Please charge the unit to full before first use using the provided USB Type-C cable. Please do not use another brand of charging cable to avoid a potential equipment malfunction. The red LED on the camera will illuminate when charging, and green LED will illuminate when reaching full charge.
 - *Charging adapter can use 5V, 1A and higher, USB Type-A port.
 - *NOT support quick charge.

- ❖ If the unit will not be used for an extended period of time, please charge at least once every 6 months to maintain the battery's health and avoid low-voltage related damage.
- ❖ **Before charging, please clean and dry the USB port on the device. Make sure there are no water droplets or moisture remaining to prevent damage to the device.**
- ❖ **Keep the metal connection between the main unit and the bracket dry. If there are water droplets, wipe them clean before magnetically buckling on.**
- ❖ Disassembling, replacing parts, or repairing this product by yourself will void the warranty.
- ❖ Do not use this product at high volume for extended periods, as it may cause hearing damage.
- ❖ The usage of communication software is similar to answering phone calls, but may vary depending on the mobile operating system (iOS/Android) or the specific communication app. If you encounter any issues, please consult the manufacturer of your mobile phone or communication app.
- ❖ Do not operate this product while riding, to avoid accidents.
- ❖ The warranty doesn't cover damages resulting from alteration, adjustment or repair by unauthorized person.

1. What's Inside

The package contains the following items. If any items are missing or damaged, please contact the original place of purchase immediately.

Main Unit	Helmet Mount (AdhesiveTape)	Metal Plate for Clip	Headset	Boom MIC (hard type)	Button MIC (soft type)
					
Felted Adhesive Pads(L)	Felted Adhesive Pad(S)	Spacer Pad	Wrench	USB Cable	E-manual/ Warranty
 (for Headset)	 (for Boom MIC)	 (for Headset)			

2. Product Overview

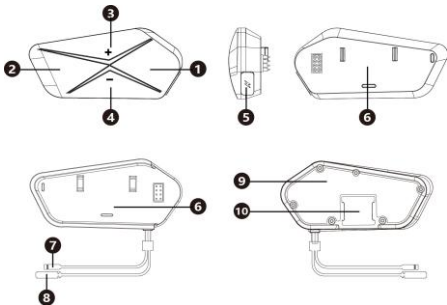

No.	Name	Function Description
1	Power Button	Power On/Off (long press), Answer/End call, Reject call (long press), Redial (double press), Play/Pause music, Switch language (double press)
2	Vibes Light / Intercom Button	Turn On/Off/Change vibes light, Enable/Disable intercom mode (long press)
3	Volume Up Button	Increase volume (long press), Enable/Disable music sharing (double press), Previous track, Multi-user intercom transmit mode
4	Volume Down Button	Decrease volume (long press), Enable/Disable auto-answer (double press), Next track, Activate phone voice assistant (double press)
5	USB Port	Connect charging cable
6	Bracket Port	Connection point between main unit and clip bracket
7	Microphone Port	Connect microphone
8	Headset Port	Connect headset
9	Adhesive Tape	Fix bracket onto helmet
10	Metal Plate slot	Fix metal plate onto bracket

3. LED Indicator & Voice Prompt

Indicator	Voice Prompt	Description
Use Single Device		
Red/Blue alternately blink	Power on	Power on and waiting for pairing
Red/Blue alternately blink	Disconnected	Bluetooth disconnected and waiting for pairing
Blue blinking	Connected	Bluetooth connected or re-connect successfully. *auto re-connect the previous paired phone.
Red blinking	Low battery, please charge	Battery power is low
All LED off	Power off	Power off
Red solid light		Charging
Green solid light		Full charged

2-person Intercom Mode

Green rapid blink	Intercom on	Waiting for intercom connection
Blue blinking	Intercom connection	Enter intercom mode

Group Intercom Mode

Red blinking	Intercom transmission mode	Group walkie-talkie in progress
Red/Blue alternately blink	Intercom reception mode	End of transmission mode

Note:

1. Before first use, use the supplied USB type-C charging cable to fully charge the device.
2. When charging is completed, ensure the USB cover is securely fitted to the device to prevent moisture intrusion. Insert the right edge of the cover into the USB port first, then press down on the left edge hardly to seal it.

4. Installation

4.1 Install Helmet Mount (Adhesive Tape) and Headset/Microphone

① Wipe and clean the area where to stick the mount and wait its surface dries. Peel off the red sheet from adhesive pad on the helmet mount, and stick and press the mount onto helmet. Then, Connect the headset and microphone to the port of clip's wire.

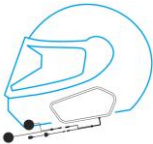

2 Install the short-wire headset on the left side of the helmet, and the long-wire headset on the right side. Once positioned, attach the headset Velcro pads to the helmet's ear recess, then press the headsets onto the Velcro to secure them. Tidy up the headsets wires and tuck them between the helmet shell and inner lining.



Note: 1.If the helmet's ear recess is too deep, use the headset spacer pad included in the package.
2. Since helmet designs vary, please adjust the installation according to your specific helmet model.

3 To install the hard-type microphone, first measure and confirm the installation position. Attach one Velcro piece to the helmet and the other to the round base of the microphone. Then press the microphone onto the Velcro on the helmet and complete the installation.



Note: To install the soft-type microphone, simply attach the back of microphone directly onto the inner lining of the helmet.

- 4 Wait for 12 hours, and then magnetically buckle the main unit to the mount and start using.



⚠ Note: Keep the metal connection between the main unit and the mount dry. If there are water droplets, wipe them clean before magnetically buckling on.

Note: After stick the mount onto helmet, it's necessary to wait for 12 hours before buckle the main unit and use.

4.2 Remove the Main Unit



4.3 Install and remove metal plate for clip mount

The Helmet Mount is designed as 2-in-1 mount, usable with both clip and adhesive type. The default mount is the adhesive type. To enable the clip mount, insert the metal plate of the clip into the slot on the back of main bracket, and push it upward until it's fully secured.

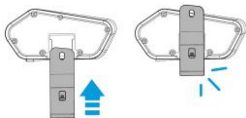

To remove the metal plate from main bracket, use the wrench provided in the package to press down the spring piece underneath the hole of metal plate toward the slot, and at the same time push the metal plate downward with your finger. Once loosened, the metal plate can be successfully removed.

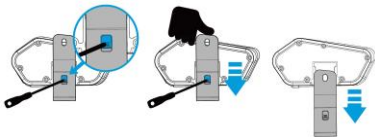

5. Initial Use

Power On/Off

Power On: Press and hold Power Button for 2 seconds.

LED: Red and blue blinking.



Power Off: Press and hold Power Button for 2 seconds.

LED: Off.



Bluetooth Pairing & Connection

After powering on, the LED flashes red and blue. Turn on your phone's Bluetooth and search for "**BT22 Pro**". Once paired successfully, a voice prompt says "**Connected**".

LED: Blue blinking.

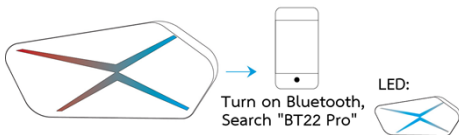

Auto Re-connect: Next time the device is powered on again, it will automatically reconnect to the last paired phone. Upon successful reconnection, a voice prompt says "**Connected**".

LED: Blue blinking.

Disconnect Bluetooth

When Bluetooth is disconnected, a voice prompt says **“Disconnected”**.
LED: Red and blue blinking.



Volume Control

Volume Up: During a call or music playback, press and hold the Volume Up Button to increase volume.



Volume Down: During a call or music playback, press and hold the Volume Down Button to decrease volume.



Music Playback / Pause

During music playback, press Power Button once to pause or resume music.

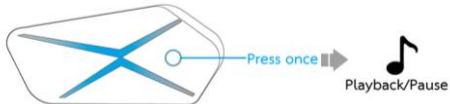

Track Control

Previous Track: During music playback, press the Volume Up Button once to switch to the previous track.

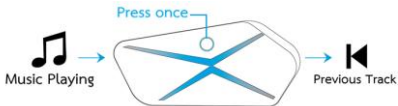

Next Track: During music playback, press the Volume Down Button once to switch to the next track.

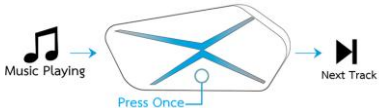

Call Control

Answer/End Call: When Bluetooth is connected, press Power Button once to answer an incoming call. During a call, press Power Button once to hang up.

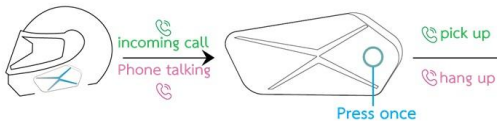

Reject Call: When receiving a call, press and hold Power Button to reject.

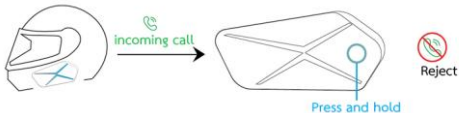

Redial Last Call: When Bluetooth is connected, press Power Button twice to redial the most recent number in the call log.

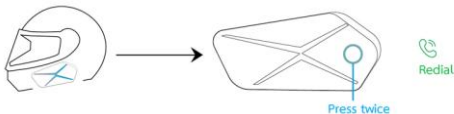

Auto Answer

When Bluetooth is not connected, press Volume Down Button twice to enable/disable auto answer.



Switch Language

When Bluetooth is not connected, press Power Button twice to switch between Chinese and English for voice prompt.



Voice Assistant Activation

When Bluetooth is connected, press Volume Down Button twice to enable/disable the phone's voice assistant.



Vibes Light Mode

While powered on, no matter Bluetooth connected or not, press Vibes Light button to cycle through the following light modes.

⚠ Note: Enabling Vibes Light Mode will reduce battery usage time.

- Press 1 time: Red light solid on
- Press 2 times: Blue light solid on
- Press 3 times: Green light solid on
- Press 4 times: Auto color changing
- Press 5 times: Auto color changing and breathing
- Press 6 times: Light reacts to sound
- Press 7 times: Turn off vibes light mode



Note: If vibes light is enabled, the light mode will remain when turning on the device next time.

Factory Default Settings (Clear Pairing)

Press and hold both Volume Up and Volume Down Buttons simultaneously to clear Bluetooth pairing information. After clearing, the device powers off.

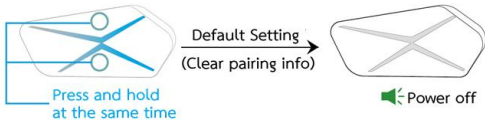

Low Battery Reminder

When battery is low, a voice prompt “**Low battery, please charge**” will repeat every 5 minutes. When the battery is depleted and the device is about to shut down, the red LED blinks as a reminder.

Note:

1. The usage of communication apps is the same as answering phone calls. However, it may vary depending on the mobile operating system (iOS/Android) or the specific communication app. If you encounter any issues, please consult the manufacturer of your mobile phone or the communication app.
2. On some Android phones, communication apps such as Line, Skype, or WeChat do not support the auto-answer function.
3. The incoming call ringtone is the default sound of the BT22 Pro system, and may not synchronize with the ringtone settings of the mobile phone.
4. On iPhone, if you find that audio remains on the phone during a call, there are two ways to switch the audio to BT22 Pro:
 - Manual Selection: On the call screen, select "MUFU_BT22 Pro" Bluetooth headset as the audio source (this must be done for each call).
 - Settings Adjustment: Go to Settings → Accessibility → Touch → Call Audio Routing and set the default value to Bluetooth Headset (when the Bluetooth headset is connected, calls will be answered through the headset).

6. Music Share

Music Share Mode allows one device to share with multiple devices (subject to Bluetooth range and environmental limitations). The operation is explained below using three devices as an example,

After connecting Headset A, B and C to Phone A, B and C via Bluetooth. Headset A playbacks music firstly, and then all of three headsets double-press Volume Up Button to enable music sharing. At this point, headset B and C can listen to the music from A. Double-press the Volume Up Button again to disable music sharing.

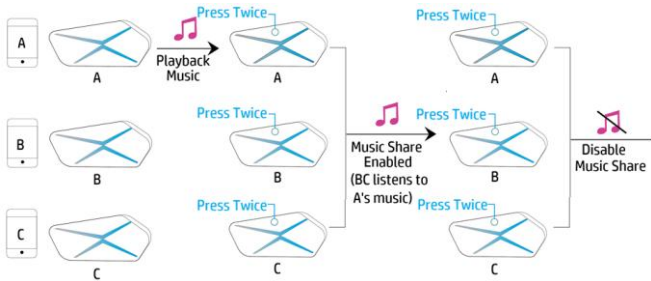

7. Intercom Mode

Enable/Disable Intercom

Power on, then long-press the Intercom Button to enable intercom mode. A voice prompt says “**Intercom on**”, and the green LED blinks rapidly for pairing. Long-press the Intercom Button again to disable intercom mode.



Two-Person Intercom Mode (Same Brand or Cross Brand)

Power on, then long-press the Intercom Button to enable intercom mode. The green LED blinks rapidly for pairing. Meanwhile, power on the other headset and enable its intercom mode as well. The BT22 Pro will automatically connect

to the other headset. Once two headsets are successfully paired, green LED off and blue LED blinks, a voice prompt says **"Intercom connection."** At this point, two-person intercom communication is available between same-brand or cross-brand headsets.

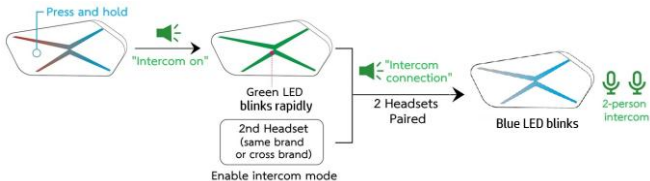

Group Intercom Mode (Same Brand Only)

 This mode does not require Bluetooth. Before enabling, please make sure that the phone's Bluetooth has been disconnected.

Power on multiple BT22 Pro headsets, and all double-press the Intercom Button. A “do” sound will be heard, and all headsets will enter Walkie-Talkie mode; red and blue LED blinks alternately. If one person wants to start a call, press the Volume Up Button once; red LED blinks. A voice prompt says “**Intercom transmission mode**,” allowing the person talk to the group. When he finishes talking, his headset will exit transmission mode, LED will resume red and blue blinks alternately, and a voice prompt will say “**Intercom reception mode**”. If any other person wants to start intercom communication, he can now press the Volume Up Button and start talking. To exit this group intercom mode, double-press the Intercom Button again, and a “du” sound will be heard.

This mode is half-duplex intercom mode, meaning only one person can speak at a time during intercom communication.

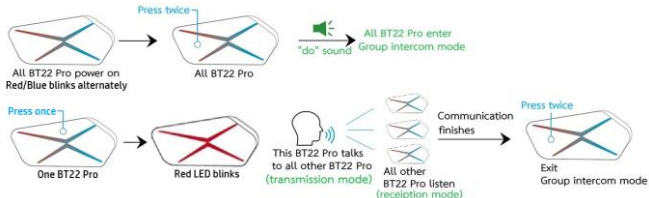

Note:

1. When one headset is engaged in a walkie-talkie call, other headsets can only stay in "reception mode" and listen. Once that headset exits "Transmission mode", other headsets may then press Volume Up button and enter "Transmission mode". "Transmission mode" allows only one headset at a time.
2. Before enabling Group Intercom Mode, please disconnect the headset from the phone's Bluetooth.
3. This mode supports at most 20 persons, and effective distance is 200 meters in open space. Signal quality varies by environment condition.

8. Pair Two Phones

The BT22 Pro can pair with two phones simultaneously. Follow the steps as below for set-up.

1. Power on BT22 Pro. Turn on Bluetooth on Phone A and complete pairing with BT22 Pro.



2. Turn off Bluetooth on Phone A. Then turn on Bluetooth on Phone B and complete pairing with BT22 Pro.



3. After successfully pairing with Phone B, turn on Bluetooth on Phone A again. The headset will automatically reconnect to Phone A. At this point, BT22 Pro is paired with both phones simultaneously.

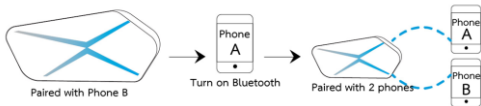

Specification

Item	Description
Bluetooth Version	6.0
Bluetooth Standard	HFP, HSP, A2DP, AVRCP
Headset	50mW Max./16ohm
Microphone	Omnidirectional
Battery	Re-chargeable 1150mAh
Charging Temperature	0° ~ 40° C
Operating Temperature	0° ~ 60° C

Item	Description
Operating Humidity	20 ~ 70% RH
Storage Temperature	-20° ~ 70° C
Size	93.5 x 43.5 x 19.0 mm (main unit)
Weight	Approximately 53.8g (main unit)

Prohibition of co-location

This device and its antenna(s) must not be co-located or operated in conjunction with any other antenna or transmitter.

WEEE Notice

Disposal of Waste Electrical and Electronic Equipment and/or Battery by users in private households in the European Union



WEEE



Battery

This symbol on the product or on the packaging indicates that this cannot be disposed of as a household waste. You must dispose of your waste equipment and/or battery by handing it over to the applicable take-back scheme for the recycling of electrical and electronic equipment and/or battery. For more information about recycling of this equipment and/or battery, please contact your city office, the shop where you purchased the equipment or your household waste disposal service. The recycling of materials will help to conserve natural resources and ensure that it is recycled in a manner that protects human health and environment.

CE Regulatory Notice

The product herewith complies with the requirements of the EMC and RED Directive 2014/53/EU and the RoHS Directive 2011/65/EU.

EU Health Protection: This equipment should be installed and operated with minimum distance 20cm between the radiator & your body.

Battery, Regulatory & Safety Notice

- ❖ This document provides country- and region-specific non-wireless and wireless regulatory notices and compliance information for your product. Some of these notices may not apply to your product.
- ❖ Disposal of a battery into fire or a hot oven, or mechanically crushing or cutting of a battery, that can result in an explosion.
- ❖ Leaving a battery in an extremely high temperature surrounding environment that can result in an explosion or the leakage of flammable liquid or gas.
- ❖ Due to local laws and for your own safety, DO NOT operate the product while riding.

- ❖ The firmware function in the product is for reference only, riders are advised to exercise discretion based on actual road conditions.
- ❖ This product is intended only for non-commercial use, within the maximum limits permitted by law. We take no responsibility for any losses as a result of use of this product.
- ❖ Bluetooth wireless signals are unable to pass through the building. The signal transmission with smart phone is up to straight-line 20 meters.
- ❖ The product employs wireless data communication which may interfere, or be interfered by, a near-by device.
- ❖ Never use this product in the vicinity of a microwave oven or at places where there is radio interference.
- ❖ Radio wave reception may be worsened in specific environments.
- ❖ Please be advised that if another product is also using the same 2.4GHz band as this product, the processing speed of both products may slow down.
- ❖ The product may get warm during use. This is normal.
- ❖ Improper use or operation of the product may result in damage to the product or its accessories and void the warranty.

- ❖ This device and its antenna(s) must not be co-located or operated in conjunction with any other antenna or transmitter.
- ❖ The radio frequency (RF) generated by this RF electronic product may cause adverse effects on the operation of other electronic product and result in malfunctioning. Wireless transmitters and circuitry may also interfere with other electronic products. Therefore, do observe the following precautions:
 - Aircraft: Never use a radio transmitter when you are in an airplane. Please switch off the wireless function of the product.
 - Vehicle: The radio frequency transmitted by this product may affect the electronic system in a motorized vehicle. Please consult the manufacturer or dealer of your vehicle on the possible effect.
 - Pacemaker: In order to prevent any potential interference to a pacemaker, anyone who uses a pacemaker should be advised, that, when using this product, a minimum distance of 15cm (6 inch) should be kept between the product and the pacemaker; and never put this product in a chest pocket. In case of any doubt of interference, switch off the product immediately.
 - Medical device: If you use a personal medical device, consult the device manufacturer or your physician to confirm if your device is sufficiently shielded from the RF transmission of this device.

- Medical Facilities: Hospitals and medical institutes may use facilities that are sensitive to an external RF energy. Observe such instructions when the medical care personnel or any posted sign requests you to switch off any device that may interfere the radio frequency.
- Explosion sites or any location with a posted sign: In order to prevent interfering with an explosion activity, observe all the signage and instructions in the Explosion Area or in a zone with a “Switch Off 2-way Radios” sign by switching off devices that may interfere with the radio frequency.

❖ MUFU is NOT responsible for the loss of any data/content during operation.

By using the product, it is assumed that you agree to all of the above statements.